

FOUR
STROKE

MFS6CS SP



Exceed the European
Union emission
standards.

FOUR
STROKE

Specifications

Type		Four Stroke
Maximum output	kW (PS)	4.4 (6)
Maximum operating range	r/min	5000-6000
Fuel consumption at W.O.T	L/Hr (gal/Hr)	2.0 (0.53)
Number of cylinder		1
Bore x Stroke	mm (in)	59x45 (2.32x1.77)
Displacement	mL (Cu in)	123 (7.51)
Engine lubrication system		Trochoid pump
Starting system		Manual
Spark plug		NGK DCPR6E
Ignition timing	degree	BTDC3°- BTDC25°
Alternator output		12V 60W 5A
Engine oil		Tohatsu 4 Stroke Engine Oil or API Standard (SH,SJ,SL) SAE 10W-30/40
Engine oil capacity	L (qt)	0.45 (0.48)
Fuel tank capacity	L (gal)	12 (3.17)
Speed control		Twist grip type
Gear reduction ratio		2.15 (13:28)
Emission Compliance		EU & EPA & CARB 3-Star

Specifications and descriptions are subject to change without notice.

Dimensions

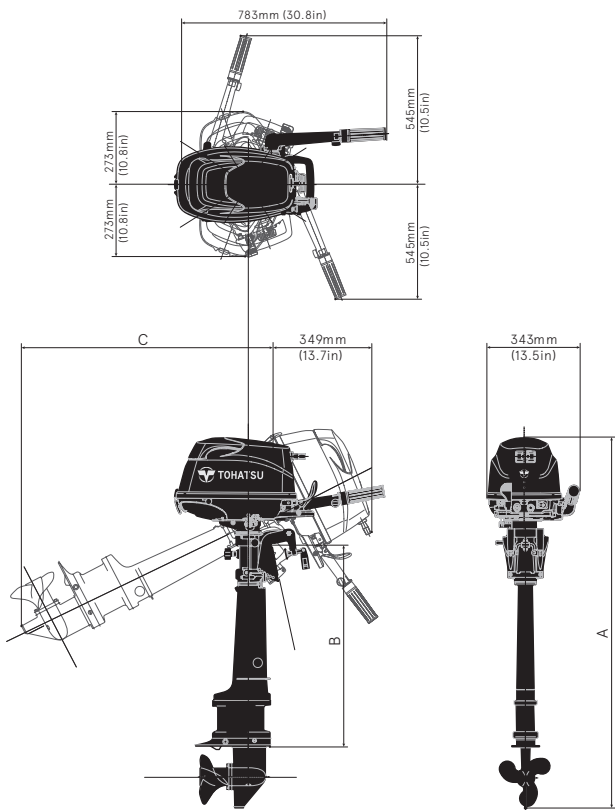

Dry Weight (kg/lbs)

Model	MF
Transom L:	26.1 (58)
Transom UL:	26.6 (59)

Dimensions (mm/in)

Model	A	B	C
Transom L:	1166 (45.9)	562 (22.1)	758 (29.8)
Transom UL:	1293 (50.9)	689 (27.1)	858 (33.8)

Standard & Optional Equipments

Type	L/UL
Electric Starter	-
Manual Recoil Starter	●
Decompression Release	●
Engine Stop Switch Lanyard	●
Alternator	●
Rectifier	●
Power Tilt	-
Transom	20/25
Propeller(High Thrust)	●
Analog Tachometer	-
Analog Trim Meter	-
Remote Control Box	-
12L (3.1 Gal) Plastic Fuel Tank	●
Tool Kit	●
Emergency Starter Rope	●
Spare Spark Plug	●
Owners Manual	●

● Standard ○ Optional



1-Cylinder



Alternator



Charging System



Thermostat



Throttle Friction



Steering Friction Adjustment
(FOR TILLER HANDLE MODEL)



High Thrust Propeller



High Solid Paint Coating



Light Weight



Sail Boat Model



Front Shift Control